

1000L IBC Tank & Frame (Food Grade)

Weights and measures:

- Nominal Capacity: 1.000
- Brimful Capacity: 1,060
- Length: 1,200mm
- Width: 1,000mm
- Height with pallet : 1,160mm
- Weight total approx: 53kg

Pallet information:

- Pallet Type: Steel frame, Pallet is Zinc plated
- Opening Height: min. 90mm, 4-way entry

Outer Container:

- Grid: Steel, Galvanised
- Bottom Plate: Steel, galvanised
- Label Plate: Large 6 field, with Schütz-Label

Inner Container:

- Rectangular blow molded tank of high density polyethylene
- Container: PE-HD, natural

Filling Opening:

- Screw Cap: DN150 / 6", PE-HD, green
- O-ring Gasket: TPE
- Without Plug

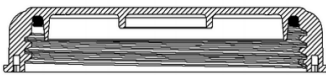

Discharge Opening:

- Outlet valve: integr.butterfly-valve DN50/2"
- Case: PE-HD
- Connection Thread: Metric
- Flap gasket/Ball gasket: PP
- Handle Colour: Green, Handle protection
- Screw Cap: PE-HD
- Screw Cap Gasket: PE, Foamed
- Screw Cap Colour: Green
- Outlet Nozzle: PE-HD, Packet

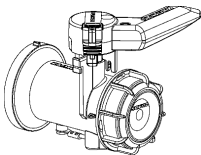

Features:

- Directive: Food safety according to FSSC 22000 and declaration of conformity
- Production: According to the 'FOODCERT'

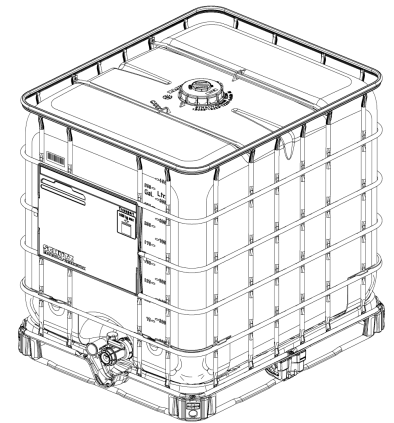
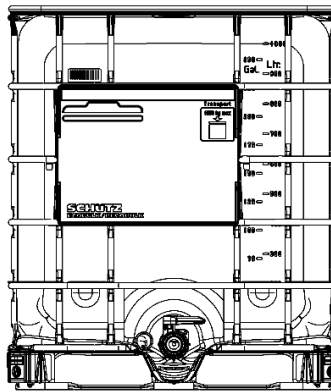

Code	Capacity (L)	Overall Size LxWxH (mm)	Unit Weight (kg)
M7684	1000	1200x1000x1160	53

1000L IBC Tank & Frame (DG Industrial Grade)

Weights and measures:

- Nominal Capacity: 1.000
- Brimful Capacity: 1,060
- Length: 1,200mm
- Width: 1,000mm
- Height with pallet : 1,160mm
- Weight total approx: 55.4kg

Pallet information:

- Pallet Type: Steel frame, Pallet is Zinc plated
- Opening Height: min. 90mm, 4-way entry

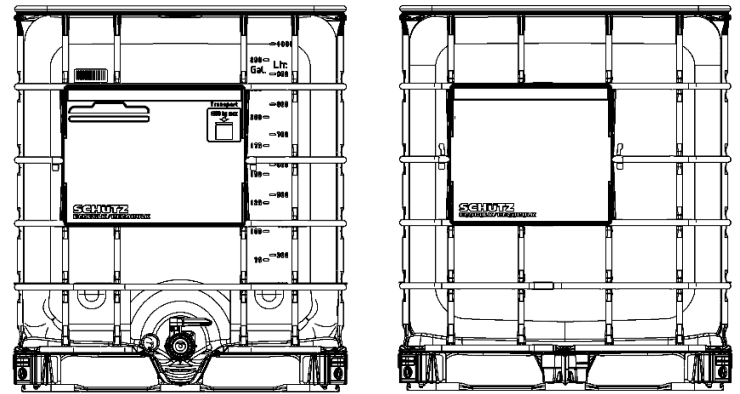

Outer Container:

- Grid: Steel, Galvanised
- Bottom Plate: Steel, galvanised
- Label Plate: Large 6 field, with Schütz-Label
- Additional Label Plate: Back side – standard

Inner Container:

- Rectangular blow molded tank of high density polyethylene
- Container: PE-HD, natural

Filling Opening:

- Screw Cap: DN150 / 6", PE-HD, RED
- O-ring Gasket: TPE
- Sealing Cap: Red

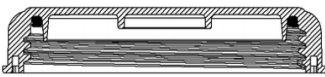

Discharge Opening:

- Outlet valve: integr.butterfly-valve DN50/2"
- Case: PE-HD
- Connection Thread: Metric
- Flap gasket/Ball gasket: PP
- Handle Colour: Blue, Handle protection
- Screw Cap: PE-HD
- Screw Cap Gasket: PE, Foamed
- Screw Cap Colour: Black
- Outlet Nozzle: PE-HD

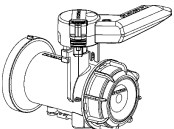

Features:

- Heavy Metals:
Concentration level of heavy metals (Pb, Cd, Cr VI and Hg) in packaging does not exceed 100 ppm
- UN-Marking:
UN_31HA1/Y/MM
YY/L/SNCH/17B001/SCHÜTZ#/4056/2037/1060L/55KG/



Code	Capacity (L)	Overall Size LxWxH (mm)	Unit Weight (kg)
M7686	1000	1200x1000x1160	55.4